



Operating instructions

Motorised pile driver "Joey"

PR-38/4T-LIGHT

BA-06-000002-01-EN

Scope of application

These Operating instructions only apply to the machine labelled on the cover sheet.

Check the machine model using the machine's rating plate.

Original instructions / translation of the original instructions

In accordance with the EU Machinery Directive, the German copy of these Operating instructions is the original instructions.

Copies in other languages are translations of the original instructions.

Kernlochbohrer GmbH

Geigersbühlweg 52

72663 Großbettlingen

Germany

Phone: +49 (0)70 22 / 50 34 900

E-mail: info@kernlochbohrer.com

Internet: <http://www.kernlochbohrer.com>

© Kernlochbohrer GmbH

This documentation is protected by copyright.

All rights to this documentation, in particular the right of reproduction, distribution and translation, are reserved by Kernlochbohrer GmbH, even in the case of applications for industrial property rights. No part of this documentation may be reproduced in any form by any means, electronic or mechanical, or processed, duplicated or distributed using electronic systems without the express written permission of Kernlochbohrer GmbH.

Subject to errors and technical changes.

Kernlochbohrer GmbH is not liable for any errors in this documentation. Liability for direct or indirect damages arising in connection with the delivery or use of this documentation is excluded to the extent permitted by law. Furthermore, Kernlochbohrer GmbH cannot be held liable for damages resulting from the infringement of patent and other rights of third parties.

The function of the machine is limited to the functions described in the associated technical documentation.

Table of contents

1	Information and support	7
1.1	Thanks to the buyer.....	7
1.2	Using the Operating instructions	7
1.3	Changes	7
1.4	Explanation of symbols	8
1.5	Guarantee	8
1.6	Environmental protection.....	9
1.6.1	Disposal of the product.....	9
1.6.2	Disposal of the packaging	9
1.7	Service	10
2	Security.....	11
2.1	General information.....	11
2.2	Intended use.....	11
2.3	Safety regulations for the operator.....	12
2.3.1	Organisational safety measures	12
2.3.2	Changes to the machine.....	12
2.3.3	Spare parts	13
2.3.4	Personnel.....	13
2.4	Safety regulations for staff.....	14
2.4.1	Safe behaviour.....	14
2.4.2	Safe operation	15
2.4.3	Protective equipment.....	16
2.5	Safety during maintenance.....	17
2.5.1	General information	17
2.5.2	Cleaning.....	17
3	Technical data	18
3.1	General.....	18
3.2	Engine	19
4	Machine description	20
4.1	Machine components and operating devices.....	20

4.2	Scope of delivery	22
5	Utilisation of the machine	23
5.1	Instructions for driving piles with a pile driver	23
5.2	Precautionary measures	25
5.3	Transport of the machine	26
5.4	Commissioning the machine	27
5.4.1	Check engine oil level	27
5.4.2	Filling the fuel tank	29
5.4.3	Attaching Path support sleeves	30
5.5	Working with the machine	31
5.5.1	Visual inspection of the machine	31
5.5.2	Start engine	32
5.5.3	Drive in pile	34
5.5.4	Switch off the machine	35
5.5.5	Cleaning the machine	36
5.5.6	Prepare machine for downtimes	37
6	Maintenance	39
6.1	Notes on proper maintenance	39
6.2	Maintenance and inspection plan	40
6.3	Inspection and maintenance	41
6.3.1	Changing the engine oil	41
6.3.2	Relubricate gearbox	44
6.3.3	Contamination Check air filter	45
6.3.4	Check fuel tank for contamination	46
6.3.5	Check spark plug	48
6.3.6	Clean the cooling fins of the motor	50
7	Troubleshooting	51
8	Spare parts	52
8.1	Pile driver	52
8.2	Engine	54
9	EU Declaration of Conformity	56

1 Information and support

1.1 Thanks to the buyer

Thank you for purchasing a machine from Kernlochbohrer GmbH.

Please read the Operating instructions carefully and observe the safety instructions. By following the Operating instructions, you will be able to fully utilise the outstanding performance of our product.

If you have any questions regarding the operation of the machine, please contact Kernlochbohrer GmbH directly. We are available to answer your questions at any time.

1.2 Using the Operating instructions

The machine is intended for professional use and may only be operated by trained personnel. Strictly adhere to the instructions in the Operating instructions.

Our company declines all responsibility in the event of non-compliance with the Operating instructions, which may result in injury or damage to the machine.

The Operating instructions are indispensable for using the machine. The Operating instructions must therefore always be kept in the vicinity of the machine and be accessible to the intended personnel at all times.

In addition to the Operating instructions, the generally applicable and local regulations for accident prevention and environmental protection must be provided; compliance with these regulations must be checked regularly.

1.3 Changes

Kernlochbohrer GmbH reserves the right to change the design and appearance of the products and their Operating instructions. Future changes to the Operating instructions will be made without prior notice.

1.4 Explanation of symbols



The symbol draws your attention to dangers that you must be aware of when carrying out the following work in order to avoid damage to yourself, other persons or property.



Cross-reference to another point in the Operating instructions.



Prerequisite for an action.



Action to be performed.



Behaviour of the machine that is to be expected as a result of the preceding action.



Background information or reference to special features.

1.5 Guarantee

In accordance with Kernlochbohrer GmbH's general terms of delivery, a warranty period of 12 months applies for material defects in business transactions with companies (proof by invoice or delivery note).

Damage caused by natural wear and tear, overloading or improper handling is excluded.

Damage caused by material or manufacturer defects will be rectified free of charge by repair or replacement. Complaints can only be recognised if the device is sent to Kernlochbohrer GmbH undismantled

Wear parts are excluded from the warranty.

1.6 Environmental protection

1.6.1 Disposal of the product

Follow national regulations on environmentally friendly disposal and recycling of used machines and accessories.

Do not dispose of the machine and accessories with household waste.

1.6.2 Disposal of the packaging

The packaging is made from recyclable materials. They must be disposed of in accordance with their labelling and municipal guidelines.

1.7 Service

Precise information and specific questions allow faults to be rectified quickly, make it easier to order spare parts and prevent incorrect deliveries.

Before contacting the service, please collect the following data first.

The model designation must be stated for all questions and orders:
This information can be found on the rating plate of the machine.

Further information is required in the event of malfunctions:
Type and extent of the malfunction, accompanying circumstances, suspected cause.

The following is required when ordering spare parts:
Quantity and item number in the exploded drawing in these Operating instructions.

Contact details:

Kernlochbohrer GmbH
Geigersbühlweg 52
72663 Großbettlingen
Germany
Phone: +49 (0)70 22 / 50 34 900
E-Mail: info@kernlochbohrer.com
Internet: <http://www.kernlochbohrer.com>

2 Security

2.1 General information

The machine was built according to the state of the art and in compliance with the applicable laws, standards and safety regulations. Use of the machine may nevertheless result in hazards for the user or third parties and damage to the machine and other property.

The machine may only be used if it is in perfect working order and in accordance with its intended use and in a safe and hazard-conscious manner.

If the machine is damaged or malfunctions, switch it off immediately, secure it against being switched on again and repair it or arrange for it to be repaired.

2.2 Intended use

The machine is designed exclusively for driving wooden, metal or concrete piles vertically into the ground.

The machine may only be used within the limits of its technical data. This information, for example performance data and ambient conditions, can be found in the "Technical data" chapter.

Any other or additional use is considered improper use - risk of accident!
Kernlochbohrer GmbH is not liable for any resulting damage. The risk is borne solely by the operator.

Intended use also includes observing the operating instructions and complying with the prescribed maintenance intervals.

2.3 Safety regulations for the operator

2.3.1 Organisational safety measures

The Operating instructions must always be available for the operating and maintenance personnel. It must therefore always be kept at the machine's place of use.

The regulations on accident prevention and environmental protection applicable at the machine's place of use must also be available. The operator of the machine must regularly check compliance with these regulations.

The use of sound-emitting machines may be limited in time by national or local regulations.

The machine must not be operated in potentially explosive atmospheres.

All safety and danger notices on the machine must be legible and must not be removed.

The protective equipment required to operate the machine must be provided by the operator. The operator must ensure that the protective equipment is used properly by the personnel.

Operating and auxiliary materials, such as lubricants or cleaning agents, must be selected in such a way that the limit values for hazardous substances applicable at the place of use are complied with. The regulations for environmental protection and disposal applicable at the place of use must be complied with.

2.3.2 Changes to the machine

The operator may not make any modifications to the machine without written authorisation from Kernlochbohrer GmbH. If the operator carries out modifications without authorisation, the warranty becomes void. Kernlochbohrer GmbH is not liable for damage caused by unauthorised modifications.

2.3.3 Spare parts

Spare parts must comply with the properties defined by Kernlochbohrer GmbH. This is always guaranteed for spare parts supplied by Kernlochbohrer GmbH. Kernlochbohrer GmbH is not liable for damage caused by the use of unsuitable spare parts.

2.3.4 Personnel

All persons who are authorised to commission, operate and maintain the machine must have read and understood the Operating instructions beforehand.

The machine may only be operated by persons who have been adequately instructed beforehand.

The machine may only be serviced by persons who have completed the appropriate specialised training for this activity.

Minors are not permitted to work with the machine. Young people over the age of 16 who are trained under supervision are exempt from this regulation.

2.4 Safety regulations for staff

2.4.1 Safe behaviour

All persons responsible for commissioning, operating and maintaining the machine must have read and understood the Operating instructions beforehand.

The machine may only be operated by persons who have been adequately instructed beforehand.

The machine may only be serviced by persons who have completed the appropriate specialised training for this activity.

Minors are not permitted to work with the machine. Young people over the age of 16 who are trained under supervision are exempt from this regulation.

Any work on and with the machine that could jeopardise safety must be avoided.

All safety and danger notices on the machine must be legible and must not be removed.

2.4.2 Safe operation

Operating the machine requires the full concentration and ability of the personnel. Persons who are overtired, unable to concentrate or under the influence of alcohol, drugs or medication must not work on or with the machine.

Persons who are not directly required to operate the machine must maintain a sufficient safety distance from the machine.

Before using the machine, check that it is in perfect condition. If the machine is damaged, it must not be used. Then secure the machine against use and repair it or arrange for it to be repaired.

In order not to jeopardise the functionality and safety of the machine, covers or other components of the machine must not be removed.

Before starting or starting up the machine, ensure that persons are not endangered by the starting machine.

Operating elements must not be operated thoughtlessly or wilfully. This could result in personal injury or damage to the machine.

When using the machine, personnel must ensure that they are standing securely and in an ergonomic posture. The machine must always be held with both hands.

The machine must not be left unattended during use.

Stopping the machine during operation with a heavy load must be avoided. This could lead to damage due to overheating.

Air inlet and outlet openings must not be covered during use.

The machine must be cleaned regularly so that dirt does not accumulate. All operating elements and handles must be kept clean, dry and free of grease.

When the machine is not in use, it must be parked in such a way that nobody is endangered. Secure the machine against unauthorised use.

2.4.3 Protective equipment

Persons using the machine are obliged to wear the following protective equipment:

- Safety shoes with non-slip sole and protective toe cap
- Safety goggles according to standard EN 166 or face protection
- Hearing protection

Persons carrying out maintenance work on the machine are obliged to wear the appropriate protective equipment required for this work.

2.5 Safety during maintenance

2.5.1 General information

The machine may only be serviced by persons who have completed the appropriate specialised training for this activity.

The maintenance activities and intervals specified in the Operating instructions must be observed.

Workshop equipment appropriate to the type of work is required to carry out maintenance activities.

The following safety precautions must be taken before starting maintenance work:

- Position the machine so that the access point is easily accessible.
- Set the machine to the appropriate operating status.

After completion of maintenance activities:

- Assemble the machine completely.
- If operating elements or safety devices have been removed, they must be refitted and their function checked.
- Retighten any screw connections that have been loosened. Re-attach the screw locks.

2.5.2 Cleaning

Do not use any corrosive, harmful or environmentally damaging substances to clean the machine.

Dispose of cleaning agents in an environmentally friendly manner.

Under no circumstances should high-pressure cleaners, water jets or compressed air be used to clean the machine.

3 Technical data

3.1 General

Model	Motorised pile driver "Joey" PR-38/4T-LIGHT
Article number	6104
Possible pile diameter	20 to 80 mm
Beat frequency	700 to 1350 1/min
Impact energy	20 to 55 joules
Width	320 mm
Depth	265 mm
Height	635 mm
Weight	12 kg
Permissible ambient temperature	-20 to +45 °C
Permissible relative humidity	Maximum 85 %
Gearbox grease	Mobil Mobilgrease XHP 222
Noise emission according to ISO 15744	
Emission sound pressure level L_{pA}	95.7 dB(A)
Sound power level L_{WA}	106.7 dB(A)
Measurement uncertainty K	3 dB(A)
Total vibration value a_h according to EN 12096	
Operating handle / idling	1.341 m/s ²
Operating handle / full load	11.869 m/s ²
Grab handle / idling	1.292 m/s ²
Grab handle / full load	11.775 m/s ²
Measurement uncertainty K	1.5 m/s ²

3.2 Engine

Combustion principle	4-stroke / OHC
Number of cylinders	1
Starter	Manual rope pull starter
Cooling	Air
Displacement	37.7 cm ³
Maximum power	1 kW / 1.36 hp at 6500 rpm
Maximum torque	1.65 Nm at 5500 rpm
Idle speed	3000± 250 1/min
Maximum speed	8500 1/min
Fuel	Petrol at least 92 RON
Fuel tank capacity	0.65 litres
Fuel consumption	≤ 0.6 litres/h
Engine oil	Universal garden tool oil 10W-30
Engine oil consumption	≤ 1.6 ml/kWh
Spark plug type	CMR7H

4 Machine description

4.1 Machine components and operating devices



- 1 Gearbox grease filler opening
- 2 Damping spring
- 3 Hammer housing
- 4 Grab handle
- 5 Carrier plate
- 6 Transport handle
- 7 Draw-wire starter
- 8 Screw plug (with dipstick) of the engine oil tank
- 9 Silencer
- 10 Control switch (on the back of the combination switch)
- 11 Stop switch on the combination switch
- 12 Throttle lever (on the back of the combination switch)
- 13 Throttle lever lock on the combination switch
- 14 Combination switch on the Operating handle
- 15 Pile pick-up
- 16 Union nut
- 17 Fuel tank
- 18 Fuel filler cap
- 19 Start flap lever
- 20 Fuel hand pump
- 21 Air filter

4.2 Scope of delivery

The scope of delivery of the "Joey" PR-38/4T-LIGHT Motorised pile driver includes the following components:

- Pile driver
- 3 Path support sleeves (Ø 25.4 mm, Ø45 mm, Ø 50.8 mm)
- Tool bag with tools
- Replacement spark plug
- Gearbox grease
- Trolley case for transport and storage
- Operating instructions



5 Utilisation of the machine

5.1 Instructions for driving piles with a pile driver

Different soil conditions can have an influence on the driving process and the stability of the driven piles. There are some important aspects to consider here:

Soil type:

The influence of the soil type on the ramming process is significant. Loamy soil has increased resistance, while sandy soil is generally less resistant. Clay soil is characterised by high adhesive strength, which can lead to increased resistance during ramming.

Soil moisture:

Soil moisture also plays an important role in the driving process. Moist soil increases the resistance of the pile, while dry soil offers less resistance. If the soil is too wet or muddy, it can be difficult to drive the pile as this leads to increased frictional resistance.

Soil conditions at depth:

It is important to consider the soil conditions at depth, as these can often differ from the surface soil layers. It is possible that the upper soil layers consist of loose material such as sand, while underneath there may be solid clay or even rock. These differences can lead to uneven driving and affect the stability of the pile.

Groundwater level:

The groundwater level is another factor influencing the driving process. A high groundwater level increases the resistance when driving in piles. The presence of water can also loosen the soil and lead to reduced stability of the driven pile.

Pile type and dimension:

The influence of soil conditions also depends heavily on the pile type and its dimensions. Different pile materials such as wood, steel or concrete each have different mechanical properties and therefore react differently to different soil conditions. It is important to select the right type of pile according to the soil conditions to ensure optimum load-bearing capacity and stability. The dimension of the pile also plays a role, as it influences the resistance and load-bearing capacity.

Soil analysis:

A comprehensive ground investigation prior to driving is essential to assess the ground conditions and identify potential difficulties or risks. Through this investigation, an informed decision can be made about the driving process to ensure optimum stability and longevity of the driven piles. The assessment of ground conditions allows appropriate precautions to be taken to overcome potential challenges, such as the use of specialised piling techniques, the adaptation of the driving process or the selection of suitable piling materials. A thorough ground investigation is an essential part of a successful piling operation and helps to identify potential problems at an early stage and find suitable solutions to ensure the stability and safety of the structure.

5.2 Precautionary measures

Before starting work, ensure that there are no lines (e.g. for electricity, water, gas) at the intended pile positions. Obtain information from local utility companies for this purpose. If in doubt, check for the presence of cables using detectors or trial excavations.

Persons using the machine are obliged to wear the following protective equipment:

- Safety shoes with non-slip sole and protective toe cap
- Safety goggles according to standard EN 166 or face protection
- Hearing protection

When using the machine, the engine produces exhaust fumes that are hazardous to health and can cause symptoms of poisoning.

The machine may therefore only be operated outdoors or in well-ventilated rooms. If the machine is operated indoors, the ambient air must be monitored. If symptoms of poisoning occur (feeling unwell, loss of consciousness, tiredness, drowsiness), switch off the machine immediately, find an area with fresh air to breathe and then consult a doctor.

When using the machine, personnel must ensure that they are standing securely and in an ergonomic posture. The machine must always be held with both hands.

The machine must not be left unattended during use.

Stopping the machine during operation with a heavy load must be avoided. This could lead to damage due to overheating.

5.3 Transport of the machine

If possible, switch off the engine before transporting the machine.

If the machine is transported with the engine running, it should only run at idle speed. Therefore, use the Transport handle for lifting and transporting. If the machine is transported using the operating handle, there is a risk of the throttle lever and throttle lever lock being actuated inadvertently.

Transport the machine as vertically as possible. To do this, carry the machine by one of the handles.

Do not touch hot machine parts, especially the silencer - risk of burns!

When transporting in vehicles: Secure the machine against falling over, damage and fuel leaks.

To prevent petrol from leaking, the fuel tank should be emptied before transporting the machine over long distances.

5.4 Commissioning the machine

5.4.1 Check engine oil level

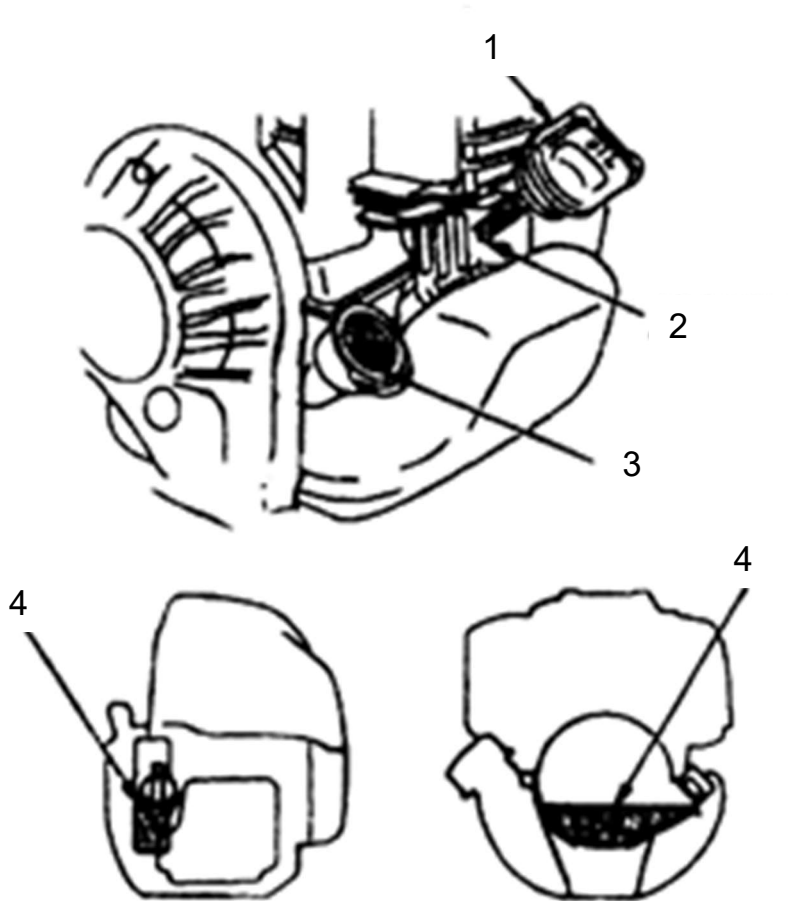

Engine oil level in the engine oil tank

- 1 Screw plug (with dipstick) of the engine oil tank
- 2 Marking on the dipstick for minimum fill level
- 3 Opening engine oil tank
- 4 Maximum fill level in the engine oil tank

- ① The machine is supplied by Kernlochbohrer GmbH with engine oil. Before starting the engine for the first time, the engine oil level must be checked as a precaution.

Procedure:

- ☑ Machine cold or at least 15 minutes after last use.
- ☒ Place the machine horizontally (filling opening for gearbox grease at the top) and secure against tipping over.
- ☒ Wait a few minutes to allow the engine oil to collect in the engine oil tank.
- ☒ Unscrew the screw plug of the engine oil tank.
- ☒ Check the fill level on the dipstick.
The level must reach at least the centre of the grooved area of the dipstick
- ☒ If there is too little engine oil in the engine oil tank, top up with oil.
Motor oil to be used:
Universal garden tool oil 10W-30 from the manufacturer LIQUI MOLY
- ☒ Check the fill level in the engine oil tank again with the dipstick
The maximum fill level must not be above the grooved area of the dipstick.
- ☒ If necessary, correct the fill level and check again.
- ☒ Fully screw in the screw plug of the engine oil tank.

- ① Note on motor oil:
The motor oil Universal garden tool oil 10W-30 from the manufacturer LIQUI MOLY recommended by Kernlochbohrer GmbH is suitable for use at ambient temperatures of approx. -20 to +45°C.

- ① The condition of the engine oil has a major influence on the operation and service life of the engine.

The engine oil must therefore be changed regularly:

- After using the machine for the first time.
- Then after the first 10 hours of operation.
- Then always after 50 hours of operation or after 6 months of real time (whichever comes first).

5.4.2 Filling the fuel tank



Special safety measures when handling petrol:

Petrol is highly flammable!

Do not spill petrol!

Keep away from naked flames!

Do not smoke!



Special safety measures when refuelling the machine:

The machine must not be refuelled when the engine is running or is still hot!

Only refuel in well-ventilated areas!

If petrol has been spilled, clean the machine immediately!

Do not allow petrol to get on clothing, otherwise change immediately!

Check for leaks! If petrol is leaking, do not start the engine!

Fuel:

Petrol (at least 92 RON) without oil additive.

Procedure:

- Machine switched off and cooled down.
- Place the machine horizontally (filler opening for gearbox grease at the top) and secure against tipping over.
- Clean the fuel tank and fuel filler cap.
- Unscrew the fuel tank cap.
- Fill petrol into the fuel tank.
- Fit the fuel filler cap on the fuel tank.
Check the fuel tank and fuel filler cap for leaks.

5.4.3 Attaching Path support sleeves

- ① The machine's Pile pick-up is designed for piles with a maximum diameter of 80 mm.

Using the supplied Path support sleeves (3 pieces with inner diameters of 25.4 mm, 45 mm and 50.8 mm) makes it easier to drive in smaller diameter piles, as these are then guided through the Path support sleeve.

Use of the Path support sleeves:

Pile diameter	Path support sleeves with inner diameter
20 mm – 25.4 mm	25.4 mm
25.4 mm – 45 mm	45 mm
45 mm – 50.8 mm	50.8 mm
50.8 mm - 80 mm	Without

Procedure:

- Machine switched off.
- Place the machine horizontally and secure it against tipping over.
- Unscrew the union nut.



- Insert the Path support sleeve into the Pile pick-up.
- Screw the union nut onto the Pile pick-up and tighten.

5.5 Working with the machine

5.5.1 Visual inspection of the machine

Before working with the machine, it must be visually inspected:

- Check the general condition and cleanliness of the machine.
- Check that all covers and machine components are present.
- Check that all screws are tight.
- Air inlet and outlet openings must not be dirty or covered.

5.5.2 Start engine

- ① Kernlochbohrer GmbH recommends only working at a low or maximum medium motor speed for the first twenty hours of operation when using the machine for the first time.
This helps the motor to run in and extends its service life.

Procedure:

- ☑ Visual inspection carried out.
- ☑ Engine oil level checked.
📖 For procedure, see chapter 5.4.1 "Check engine oil level".
- ☑ Fuel tank filled and closed.
📖 For the procedure, see chapter 5.4.2 "Filling the fuel tank".
- ☑ Path support sleeves attached if necessary (depending on the pile diameter).
📖 For procedure, see chapter 5.4.3 "Attaching Path support sleeves".
- ☒ Push the Stop switch on the Combination switch downwards (switch position "1").
- ☒ Set up the machine vertically (motor on top) and secure against falling over.
- ☒ Squeeze the bellows of the fuel hand pump several times.
↳ Carburettor is filled with petrol



- ☒ When the engine is cold:
Close the starter flap. To do this, move the starter flap lever to the side opposite the fuel tank.



Start flap closed
(start flap lever
away from the fuel tank)



Start flap open
(start flap lever
to the fuel tank)

- ☒ Hold the machine by the Transport handle with one hand.
Grip the pull handle of the pull-wire starter with the other hand.
Pull the pull-wire starter out jerkily by approx. 50 cm.
↪ Engine starts.
Sometimes several pulling movements are required to start the engine.



Do not allow the pull handle to snap back freely when pulling repeatedly, but hold it firmly to prevent injuries caused by rapid retraction.

- ☒ Continue to hold the machine by the Transport handle.
 - ☒ After starting the engine:
Open the starter flap completely. To do this, push the starter flap lever towards the fuel tank.
 - ☒ Run the engine at idling speed for approx. 5 minutes to bring it up to operating temperature.
- ① Do not pull the pull-cord starter handle when the engine is running!
This could damage the pull-wire starter.

5.5.3 Drive in pile



Two people are required to drive a pile:
The first person operates the machine, while the second person positions the pile and aligns it in the driving direction.



The second person must wear the same protective equipment as the person operating the machine.



When placing the machine on the pole, there is a risk of crushing body parts between the machine and the pole.
Only hold the machine by the handles.
Hold the pole at a sufficient distance from the machine.



Do not touch hot machine parts, especially the silencer - risk of burns.

Procedure:

- Engine started and at operating temperature.
- The pile is positioned and securely fixed by another person.
This person must position themselves in such a way that they are not in the exhaust gas flow of the machine when driving in the pile.
- Place the machine's Pile pick-up on the pile to be driven:
The machine can initially be held by the Grab handle and Transport handle.
If the machine is held by the operating handle, the throttle lever and throttle lever lock must not be actuated at the same time.
- Set the motor speed using the control switch.
Kernlochbohrer GmbH recommends working at a maximum medium speed. This protects the motor and extends its service life.
- Hold the machine firmly to drive in the pile:
The right hand grips the machine by the operating handle and operates the throttle lock and throttle lever.
The left hand grips the machine by the Grab handle.
↳ The pile is driven into the ground by the machine.

- ☒ While driving in the pile, constantly ensure that the machine is securely positioned on the pile and that the driving direction is correct.
- ☒ When the desired depth of the pile has been reached:
Continue to hold the machine with both hands, but
Release the throttle lever and throttle lever lock.
- ☒ Remove the machine from the pole.
The machine can be held by the Transport handle.
When the machine is held by the operating handle, the throttle lever and throttle lever lock must not be operated at the same time.
- ☒ If the machine is parked with the motor running or still hot during work breaks, it must be stored on a non-flammable surface and secured against falling over or tipping over.



To refill petrol, see chapter 5.4.2 "Filling the fuel tank".

5.5.4 Switch off the machine

Procedure:

- ☑ Park the machine with the engine running on a non-flammable surface and secure it against falling over or tipping over.
- ☒ Run the engine at idling speed for approx. 3 to 5 minutes to allow it to cool down.
- ☒ Switch off the motor at the Combination switch on the Operating handle:
To do this, press in the stop switch lock.
Then push the Stop switch upwards (switch position "0").



- ↵ The machine motor is switched off.
- ☒ Push the Stop switch on the Combination switch downwards (switch position "1").

5.5.5 Cleaning the machine

When work with the machine is finished for the day, the machine must be cleaned.



Do not use sharp sponges or metal objects to clean the machine. These could damage the surface of the machine.

Do not use high-pressure cleaners, water jets or compressed air to clean the machine. The sharp water or air jet could damage the machine.

Do not use any corrosive, harmful or environmentally damaging substances to clean the machine.

Auxiliary means:

Container with a mixture of water and mild detergent (e.g. washing-up liquid).

Procedure:

- Machine and motor have cooled down completely.
- Set up the machine vertically (motor on top) and secure against falling over.
- Clean the machine to remove dust and dirt.
To do this, use a cloth dipped in water mixed with a mild detergent.
Do not allow water to enter the interior of the housing via the ventilation openings.
- Clean the air inlet and outlet openings with a brush and cloth.
- All operating elements and handles must be clean, dry and free of grease.
- Store the machine in a dry, cool place protected from moisture and direct sunlight.
In the event of a brief standstill: Fill the fuel tank with petrol.
Park the machine vertically and secure it against falling over.
Secure the machine against unauthorised use.



5.5.6 Prepare machine for downtimes

If the machine is not to be used for longer than 1 month, the machine's fuel system must first be completely drained.

Auxiliary means:

Petrol-resistant container (capacity of approx. 2 litres)

Procedure:

-  For safety measures for handling petrol, see chapter 5.4.2 "Filling the fuel tank".
- Machine and motor have cooled down completely.
- Machine cleaned.
 -  For the procedure, see chapter 5.5.5 "Cleaning the machine".
- Set up the machine vertically (motor on top) and secure against falling over.
- Clean the fuel tank and fuel filler cap.
- Unscrew the fuel tank cap.
- Pour the petrol out of the fuel tank opening by tilting the machine. Collect the petrol in a container and dispose of it in accordance with regulations and the environment.
- Fit the fuel filler cap on the fuel tank.
- Squeeze the bellows of the fuel hand pump at least five times.



- Start the engine and let it idle until the engine stops.
- Allow the machine and motor to cool down completely.

- ☒ Store the machine in a dry, cool place protected from moisture and direct sunlight.
Park the machine vertically and secure it against falling over.
Secure the machine against unauthorised use.

6 Maintenance

6.1 Notes on proper maintenance

Insufficient or improper maintenance can cause malfunctions and impair the operational safety and service life of the machine. Regular inspection and maintenance is therefore essential. We recommend that maintenance work is only carried out by trained personnel.

The contractually agreed warranty does not release the operator of the machine from the obligation to maintain the machine in accordance with the manufacturer's instructions from the time of commissioning. Kernlochbohrer GmbH is not liable for damage caused by a lack of maintenance.

6.2 Maintenance and inspection plan

The interval specifications refer to normal operating conditions. In more difficult conditions (heavy dust accumulation, etc.) and longer daily working times, the specified intervals must be shortened accordingly by the operator.

Only use the maintenance and inspection schedule as a guide! Be sure to observe the cross-references in chapter 6.3! This contains a detailed description of how to carry out the individual tasks correctly and safely.

Interval	Category	Component	Activity	Chapter
10 h	Operating time	Engine	Change the oil	6.3.1
50 h	Operating time	Gearbox	Regreasing	6.3.2
50 h / 26 w	Operating time / real time	Engine	Change the oil	6.3.1
4w	Real time	Air filter	Check contamination	6.3.3
4 w	Real time	Fuel tank	Check contamination	6.3.4
4 w	Real time	Spark plug	Check condition	6.3.5
4 w	Real time	Engine	Clean cooling fins	6.3.6

Abbreviations for time units:

h Hour

w week

6.3 Inspection and maintenance

6.3.1 Changing the engine oil

- ① The condition of the engine oil has a major influence on the operation and service life of the engine.

The engine oil must therefore be changed regularly:

- After using the machine for the first time.
- Then after the first 10 hours of operation.
- Then always after 50 hours of operation or after 6 months of real time (whichever comes first).

Interval:

After using the machine for the first time or
10 hours of operation or
50 hours of operation or after 6 months Real time

Fuel:

Universal garden tool oil 10W-30 from the manufacturer LIQUI MOLY

Quantity: 100 ml

- ① The specified quantity was determined during the initial filling. It only serves as a reference for procuring the oil!
When filling the machine, the level read off the dipstick is decisive.

Auxiliary means:

Oil-resistant container (capacity of approx. 1 litre)

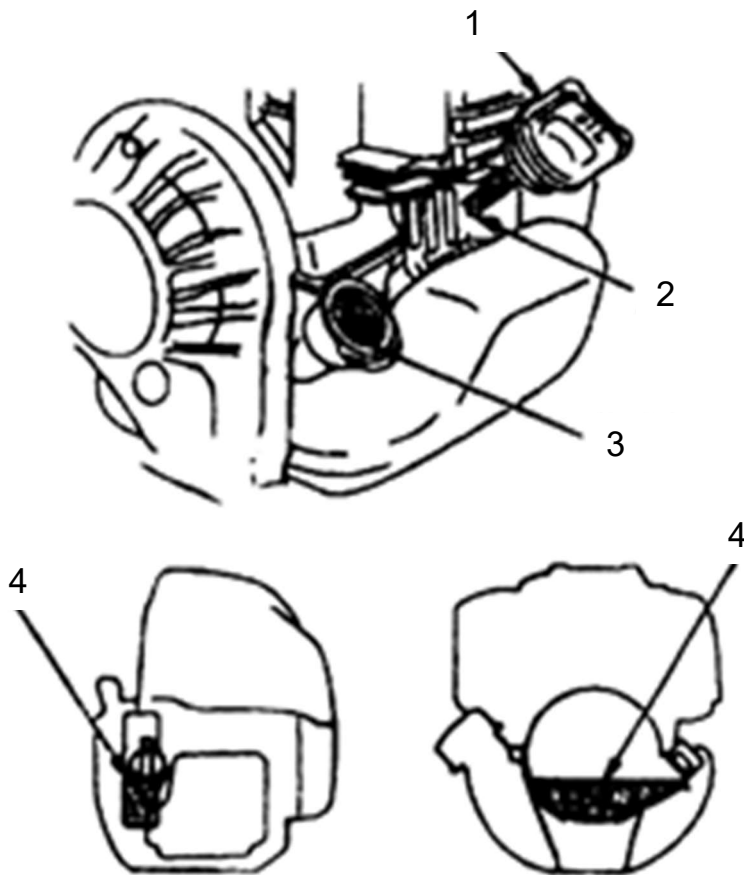

Engine oil level in the engine oil tank

- 1 Screw plug (with dipstick) of the engine oil tank
- 2 Marking on the dipstick for minimum fill level
- 3 Opening engine oil tank
- 4 Maximum fill level in the engine oil tank

Procedure:

- Machine at operating temperature.



Do not touch hot machine parts, especially the silencer - risk of burns!

- Place the machine in a vertical position on a non-flammable surface and secure it against falling over.
- Clean the engine oil tank and the screw plug of the engine oil tank.
- Unscrew the screw plug of the engine oil tank.

- ☒ Pour the engine oil out of the opening of the engine oil tank by tilting the machine.

Collect the engine oil in a container and dispose of it in accordance with regulations and the environment.

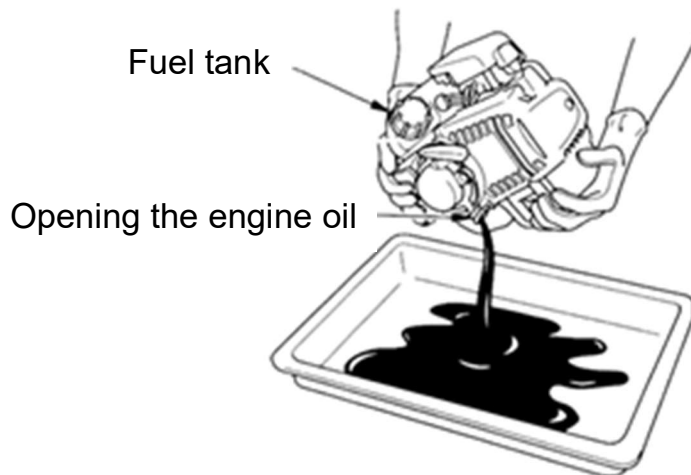

- ☒ Place the machine horizontally (filler opening for gearbox grease at the top) and secure against tipping over.
- ☒ Fill the engine oil tank with engine oil.
 - ① The specified quantity of 60 ml was determined during the initial filling. It only serves as a reference for procuring the oil!
When filling the machine, the level read off the dipstick is decisive.
- ☒ Fully screw in the screw plug of the engine oil tank.
- ☒ Unscrew the screw plug of the engine oil tank.
- ☒ Check the fill level on the dipstick.

The fill level must reach at least the centre of the grooved area of the dipstick

The maximum fill level must not be above the centre of the grooved area of the dipstick.
- ☒ If necessary, correct the fill level and check again.
- ☒ Fully screw in the screw plug of the engine oil tank.
- ① Note on motor oil:

The motor oil Universal garden tool oil 10W-30 from the manufacturer LIQUI MOLY recommended by Kernlochbohrer GmbH is suitable for use at ambient temperatures of approx. -20 to +45°C.

6.3.2 Relubricate gearbox

Interval:

50 hours operating time

Fuel:

Gearbox grease Mobilgrease XHP 222 from the manufacturer Mobil.

Quantity: 50 g

Procedure:

- Machine and motor have cooled down completely.
- Place the machine horizontally (filler opening for gearbox grease at the top) and secure against tipping over.
- Clean dust and dirt from the machine in the area of the gearbox.
- Remove the cover of the filler opening for gearbox grease.
- Fill the gearbox grease into the gearbox.



- Fit the cover of the filler opening for the gearbox grease.

6.3.3 Contamination Check air filter

- ① If the machine is used in a very dusty environment, the maintenance interval may have to be shortened by the operator.

A dirty air filter reduces performance and shortens the service life of the engine.

Interval

4 weeks real time

Auxiliary means:

Container with a mixture of water and mild detergent (e.g. washing-up liquid).

Procedure:

- Machine and motor have cooled down completely.
- Place the machine horizontally (filling opening for gearbox grease at the top) and secure against tipping over.
- Clean dust and dirt from the machine in the area of the air filter.
- Remove the air filter cover.
- Remove the filter element from the air filter housing.
- Check the filter element for soiling.
Clean the dirty filter element in water mixed with a mild detergent and then dry thoroughly.
- Check the filter element for damage. Replace damaged filter element.
- Clean the cover of the air filter and the inside of the air filter housing.
To do this, use a cloth dipped in water mixed with a mild detergent and then dry thoroughly.
- Insert the filter element into the air filter housing.
- Fit the air filter cover.

6.3.4 Check fuel tank for contamination

Interval

4 weeks real time

Procedure:

- Machine and motor have cooled down completely.
- Place the machine horizontally (filling opening for gearbox grease at the top) and secure against tipping over.
- Clean dust and dirt from the machine in the area of the fuel tank.
- Check the interior of the transparent fuel tank for deposits.
- If deposits are visible inside the fuel tank:
Clean the fuel tank and replace the fuel filter.

Clean the fuel tank and replace the fuel filter

Auxiliary means:

Petrol-resistant container (capacity of approx. 2 litres)

Sturdy metal wire with hook at one end.

Fuel:

Petrol (at least 92 RON) without oil additive

Procedure:

-  For safety measures for handling petrol, see chapter 5.4.2 "Filling the fuel tank".
- Machine and motor have cooled down completely.
- Place the machine horizontally (filling opening for gearbox grease at the top) and secure against tipping over.
- Clean dust and dirt from the machine in the area of the fuel tank.

- ☒ Clean the fuel tank and fuel filler cap.
- ☒ Unscrew the fuel tank cap.
- ☒ Pour the petrol out of the fuel tank opening by tilting the machine. Collect the petrol in a container and dispose of it in accordance with regulations and the environment.
- ☒ Clean the interior of the fuel tank. Remove deposits.
- ☒ Pull the fuel line out of the fuel tank at the fuel filter using the metal wire.



- ☒ Disconnect the fuel filter from the fuel line and dispose of it in accordance with regulations and the environment.
- ☒ Fit a new fuel filter to the fuel line.
- ☒ Insert the fuel line with fuel filter into the fuel tank.
- ☒ Fill petrol into the fuel tank.
- ☒ Fit the fuel filler cap on the fuel tank.
Check the fuel tank and fuel filler cap for leaks.

6.3.5 Check spark plug

Interval

4 weeks real time

Auxiliary means:

Wire brush

Procedure:

- Machine and motor have cooled down completely.
- Place the machine horizontally (filling opening for gearbox grease at the top) and secure against tipping over.
- Clean dust and dirt from the area around the motor.
- Remove the motor cover.
- Remove the spark plug cap from the spark plug.
- Unscrew the spark plug from the engine.
- Clean the spark plug. Remove carbon deposits in the area of the electrodes with a wire brush.
- ① Eliminate the cause of the spark plug contamination.
Possible causes are Contaminated air filter, unfavourable operating conditions.
- Check the condition of the spark plug and especially the electrodes.
If the spark plug is damaged or the electrodes are burnt out, the spark plug must be replaced. Use a new CMR7H spark plug.

- ☒ Check electrode gap.
The electrode gap must be 0.5 to 0.7 mm.
Correct the electrode gap if necessary.

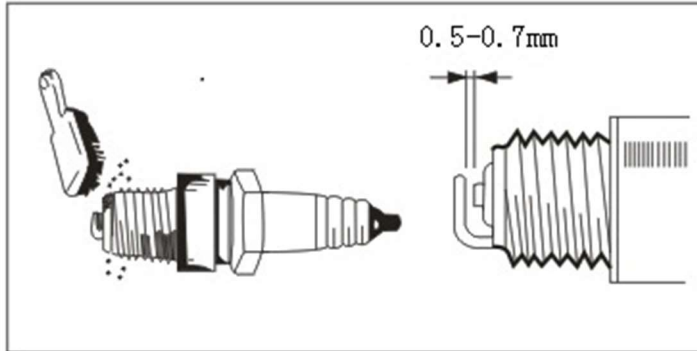

- ☒ Screw the spark plug into the engine.
- ☒ Fit the spark plug cap.
- ☒ Fit the motor cover.

6.3.6 Clean the cooling fins of the motor

- ① The machine is equipped with an air-cooled motor. Good heat dissipation via the cooling fins of the motor is crucial for trouble-free long-term operation. Dirt on the cooling fins impairs heat dissipation and must therefore be removed regularly.



Do not use sharp sponges or metal objects to clean the machine. These could damage the surface of the machine.

Do not use high-pressure cleaners, water jets or compressed air to clean the machine. The sharp water or air jet could damage the machine.

No corrosive, harmful or environmentally damaging substances may be used to clean the machine.

Interval

4 weeks real time

Auxiliary means:

Container with a mixture of water and mild detergent (e.g. washing-up liquid).

Procedure:

- Machine and motor have cooled down completely.
- Place the machine horizontally (filling opening for gearbox grease at the top) and secure against tipping over.
- Clean dust and dirt from the area around the motor.
- Remove the motor cover.
- Remove dust, dirt and deposits from the motor's cooling fins. To do this, use a cloth dipped in water mixed with a mild detergent.
- Fit the motor cover.

7 Troubleshooting

If a fault occurs during operation of the machine, please first try to rectify the fault yourself using the following information.

If you are unable to rectify the fault yourself, please contact Kernlochbohrer GmbH.

Malfunction	Possible cause	Troubleshooting	Chapter
Difficulties starting the cold engine	Check whether the spark plug is wet.	Clean the spark plug.	6.3.5
	Check whether spark plug produces a spark.	Replace spark plug.	6.3.5
Difficulty starting after a sudden stop	Check whether fuel has been consumed.	Fill the fuel tank.	5.4.2
	Check whether the fuel filter is clogged.	Replace the fuel filter.	6.3.4
	Check for carbon deposits on the spark plug electrodes.	Clean the spark plug and air filter.	6.3.5 + 6.3.3
	Check whether the carburettor is clogged.	Clean the carburettor.	
Slow speed or poor performance	Check whether the fuel line or fuel filter is clogged.	Clean or replace	6.3.4
	Check whether the air filter is clogged.	Clean the air filter.	6.3.3
Unusual noise development	Check whether there is heavy wear on the moving parts.	Replace worn parts.	

8 Spare parts

8.1 Pile driver

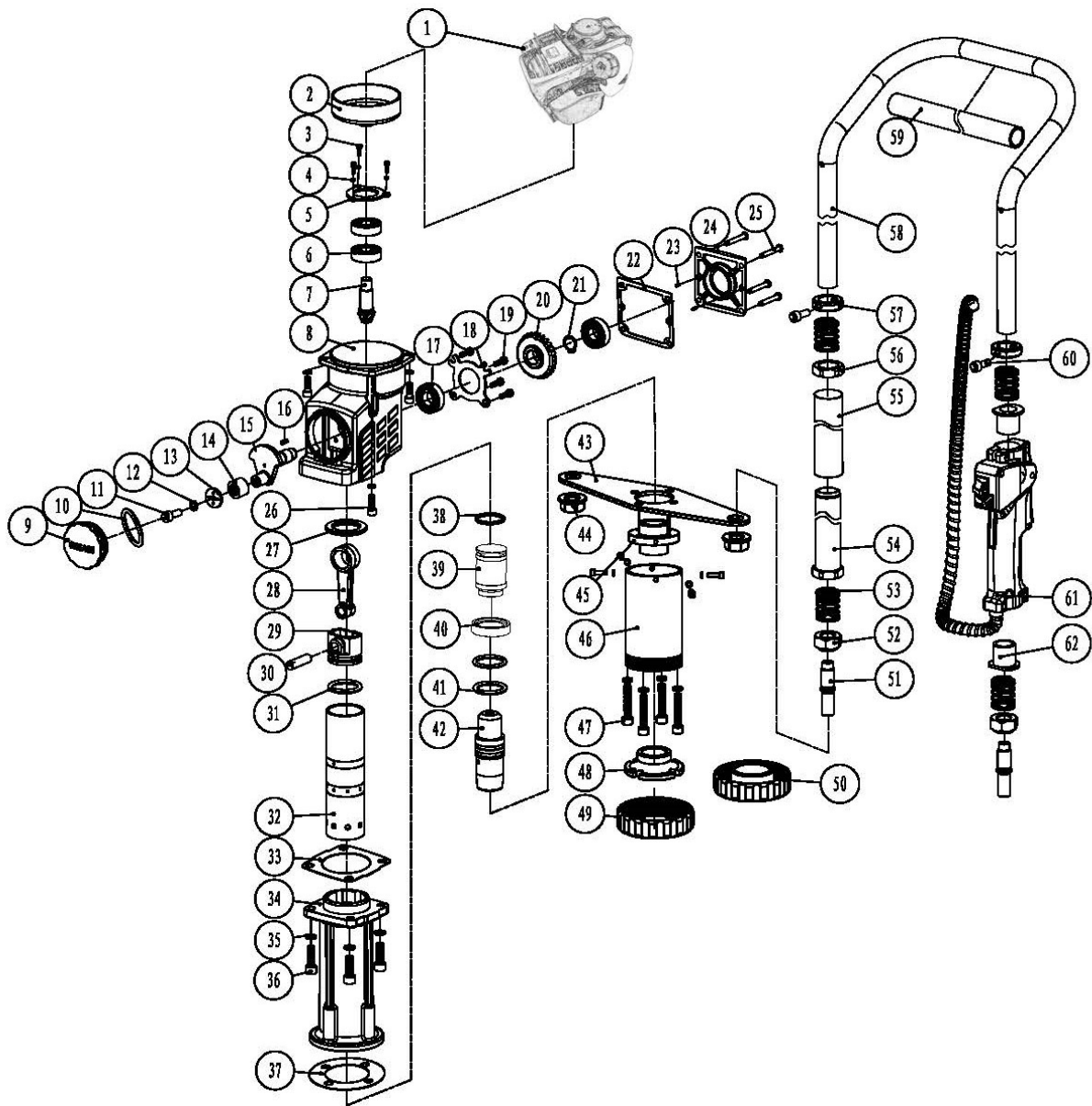

No.	Designation	Quantity
1	XY139 petrol engine	1
2	Traction sheave	1
3	Allen screw with hexagon socket M5×12	3
4	Elastic washer 5	3
5	Bearing pressure plate	1
6	Deep groove ball bearing 6202-2RS	3
7	Small bevel gear 7-2	1
8	Reduction gearbox	1
9	Oil cap	1
10	O-ring 50x1.5 for oil cap	1
11	Allen screw with hexagon socket M6× 16	1
12	Elastic washer 6	9
13	Holder	1
14	Needle roller bearing HK152316	1
15	Crankshaft	1
16	Parallel key A5x5x10	1
17	Deep groove ball bearing 6003-2RS	1
18	Bearing pressure plate 6003	1
19	Phillips screw M5x14	4
20	Large bevel gear 28-2	1
21	Shaft lock 16	1
22	Rear paper support	1
23	Parallel pin 4x10	2
24	Cover for reduction gearbox	1
25	Allen screw with hexagon socket M5× 20	4
26	Allen screw with hexagon socket M6× 20	8
27	Cylinder gasket	1
28	Connecting rod	1
29	Piston	1
30	Impact piston pin	1
31	Ring Piston ring	

No.	Designation	Quantity
32	Cylinder	1
33	Medium paper circulation	1
34	Front flap	1
35	Elastic washer 8	8
36	Allen screw with hexagon socket M8× 20	4
37	Front paper support	1
38	Hammer ring	1
39	Hammer	1
40	Circlip	2
41	Impact ring	2
42	Impact	1
43	Support plate	1
44	Hexagon flange nut M18x1.5	2
45	Impact mandrel	11
46	Ramming nozzle	1
47	Allen screw with hexagon socket M8× 20	4
48	Inner pile head 77	1
49	Path support sleeve 80	1
50	Path support sleeve 45	1
51	Connection thread head	2
52	Step nut	2
53	Handle spring 38x27x2.5	4
54	Handle	1
55	Soft handle	1
56	Handle nut	1
57	Positioning sleeve	2
58	Handle frame	1
59	Soft grip frame	1
60	Allen screw with hexagon socket M6× 40	2
61	Combination switch	1
62	Switch handle Guide sleeve	2

8.2 Engine

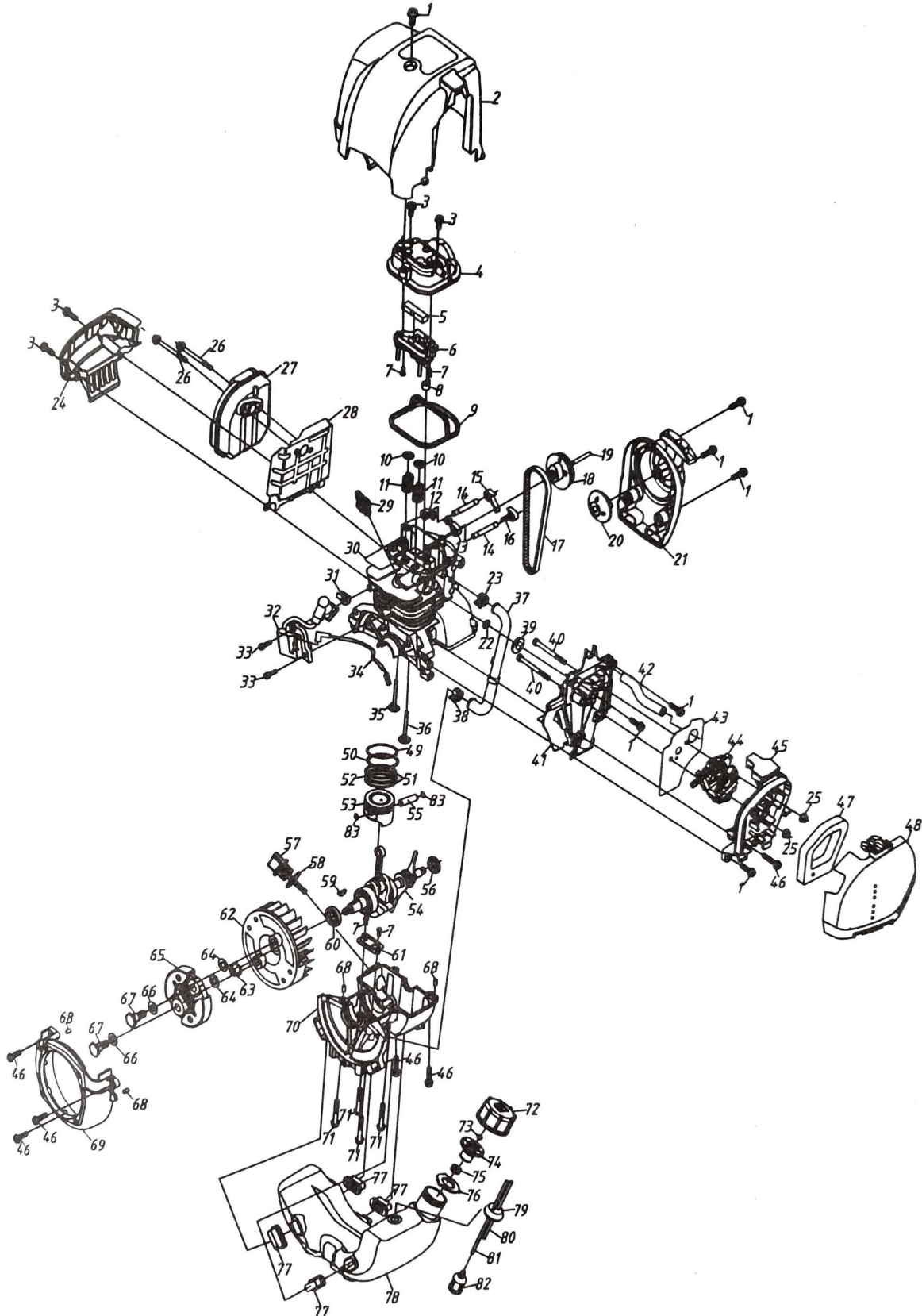

No.	Designation	Quantity
1	Flange screw M5X15	7
2	Cylinder cover	1
3	Flange screw M5x12	3
4	Air door cover	1
5	Oil-gas separator	1
6	Inner shielding cylinder	1
7	M4x8 screw	4
8	Sealing ring	1
9	Air shield Sealing ring	1
10	Air door suspension seat	2
11	Air doors	2
12	Exhaust rocker arm	1
13	Inlet rocker arm	1
14	Rocker arm bolt	2
15	Exhaust rocker arm Pull block	1
16	Inlet rocker arm pull block	1
17	Synchronised band	1
18	Cam gear	1
19	Cam pin roll	1
20	Starting disc	1
21	Starter motor	1
22	Intake manifold flat gasket	1
23	Small ring	1
24	Silencer lower shield	1
25	Flange nut M5	2
26	Screw Assembly	2
27	Muffler	1
28	Muffler Silencer	1
29	Spark plug	1
30	Cylinder	1
31	High-voltage terminal	1
32	Magnetor stator	1
33	Mounting screw M4x14	2
34	Stop line	1
35	Exhaust flap	1
36	Entrance door	1
37	Equalising tube	1
38	Small ring (A)	1
39	Intake manifold sealing ring	1
40	Nut M5X55	2
41	Intake manifold part	1
42	Waste pipe	1

No.	Designation	Quantity
43	Carburettor gasket	1
44	Carburettor	1
45	Air filter inner cover	1
46	Flange screw M5x22	6
47	Filter element	1
48	Air filter housing	1
49	First piston ring	1
50	Second piston ring	1
51	Squeegee	2
52	Shock absorber spring	1
53	Piston	1
54	Mounting the crankshaft	1
55	Piston pin	1
56	Small seal	1
57	Oil level indicator	1
58	O-ring14x2.65	1
59	Woodruff key 3x5x13	1
60	Large oil seal	1
61	Spring plates	1
62	Magnetic rotator	1
63	Nut M8	1
64	Seal B	2
65	Clamping block assembly	1
66	Wave former disc	2
67	Screw Shaft	1
68	Pin B4x8	4
69	Magnetor housing	1
70	Lower crankshaft	1
71	Flange screw M5x32	4
72	Fuel tank cap	1
73	Intake manifold	1
74	Inner lid oil tank	1
75	End cap	1
76	Stuffing box	1
77	Rubber shock absorber	4
78	Oil tank	1
79	Pipe plugs	1
80	Oil return line	1
81	Oil inlet pipe	1
82	Heating oil filter	1
83	Piston pin holder	2

9 EU Declaration of Conformity

The manufacturer/distributor

Kernlochbohrer GmbH
Geigersbühlweg 52
72663 Großbettlingen
Germany

hereby declares that the following product

Product description: **Motorised pile driver**

Type: **PR-38/4T-LIGHT**

complies with all relevant provisions of the applicable legal regulations (hereinafter) - including their amendments valid at the time of the declaration. This declaration of conformity is issued under the sole responsibility of the manufacturer. This declaration relates only to the machine in the state in which it was placed on the market; parts and/or modifications subsequently fitted by the end user are not taken into account.

The following legal provisions were applied:

Machinery Directive 2006/42/EC

The following harmonised standards were applied:

EN ISO 12100 Safety of machinery - General principles for design - Risk assessment and risk reduction (ISO 12100:2010)

EN 62841 Electric motor-operated hand-held tools, transportable tools and lawn and garden machinery - Safety - Part 1: General requirements (IEC 62841-1:2014, modified + Cor. 1:2014 + Cor. 2:2015); German version EN 62841-1:2015 + AC:2015

Name and address of the person authorised to compile the technical documentation:

Kernlochbohrer GmbH | Geigersbühlweg 52 | 72663 Großbettlingen | Germany

Großbettlingen 2025-04-14

Kernlochbohrer GmbH

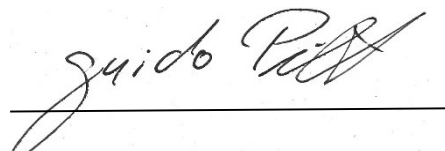

Guido Pillat

Managing Director / Chief Executive Officer