



KERNLOCHBOHRER[®]
PROFESSIONAL POWER TOOLS



Operating instructions
Underfloor heating milling machine
T-REX

BA-03-000001-01-EN

Scope of application

These Operating instructions only apply to the machine labelled on the cover sheet.

Check the machine model using the machine's rating plate.

Original instructions / translation of the original instructions

The German copy of these Operating instructions is the original instructions in accordance with the EU Machinery Directive.

Copies in other languages are translations of the original instructions.

Kernlochbohrer GmbH

Geigersbühlweg 52

72663 Großbettlingen

Germany

Phone: +49 (0)70 22 / 50 34 900

E-mail: info@kernlochbohrer.com

Internet: <http://www.kernlochbohrer.com>

© Kernlochbohrer GmbH

This documentation is protected by copyright.

All rights to this documentation, in particular the right of reproduction, distribution and translation, are reserved by Kernlochbohrer GmbH, even in the case of applications for industrial property rights. No part of this documentation may be reproduced in any form by any means, electronic or mechanical, or processed, copied or distributed using electronic systems without the express written permission of Kernlochbohrer GmbH.

Subject to errors and technical changes.

Kernlochbohrer GmbH is not liable for any errors in this documentation. Liability for direct or indirect damage arising in connection with the delivery or use of this documentation is excluded to the extent permitted by law. Furthermore, Kernlochbohrer GmbH cannot be held liable for damages resulting from the infringement of patent and other rights of third parties.

The function of the machine is limited to the functions described in the associated technical documentation.

Table of contents

1	Information and support	6
1.1	Thanks to the buyer.....	6
1.2	Using the Operating instructions	6
1.3	Modifications	6
1.4	Explanation of symbols	7
1.5	Warranty	7
1.6	Environmental protection.....	8
1.6.1	Disposal of the product.....	8
1.6.2	Disposal of the packaging	8
1.7	Service	9
2	Safety and security.....	10
2.1	General information.....	10
2.2	Intended use.....	10
2.3	Safety regulations for the operator	11
2.3.1	Organisational safety measures	11
2.3.2	Modifications to the machine	11
2.3.3	Spare parts	12
2.3.4	Personnel.....	12
2.4	Safety regulations for personnel	13
2.4.1	Safe behaviour.....	13
2.4.2	Safe operation	14
2.4.3	Protective equipment.....	15
2.5	Safety during maintenance.....	16
2.5.1	General information	16
2.5.2	Cleaning.....	16
3	Technical data	17
4	Machine description	18
4.1	Machine components	18
4.2	Operating elements	20
4.3	Explanations of machine components and operating elements.....	21

4.3.1	Connecting plug.....	21
4.3.2	Emergency stop button.....	21
4.3.3	Switch for spindle motor	21
4.3.4	Milling depth display	22
4.3.5	Adjusting the milling depth.....	22
4.3.6	Laser pointer.....	22
4.4	Further interfaces	23
4.4.1	Connection for dust extraction.....	24
4.4.2	Connection for water supply	24
4.5	Scope of delivery.....	25
5	Use of the machine	26
5.1	Specific precautions	26
5.2	Transporting the machine.....	27
5.2.1	Transport on fixed castors	27
5.2.2	Transport with the upper part of the operating arm folded down.....	27
5.2.3	Transporting the individual components.....	28
5.3	Working with the machine	30
5.3.1	Visual inspection of the machine	30
5.3.2	Fitting the milling disc	30
5.3.3	Electrical connection.....	33
5.3.4	Using the machine	34
5.3.5	Switching off the machine.....	37
5.3.6	Storing the machine.....	38
6	Maintenance.....	39
6.1	Notes on proper maintenance.....	39
6.2	Maintenance and inspection schedule	39
6.3	Inspection and maintenance	40
6.3.1	Cleaning the machine and checking.....	40
7	Troubleshooting.....	41
8	Spare parts	42
9	EU Declaration of Conformity.....	44

1 Information and support

1.1 Thanks to the buyer

Thank you for purchasing a machine from Kernlochbohrer GmbH.

Please read the Operating instructions carefully and observe the safety instructions. By following the Operating instructions, you will be able to fully utilise the outstanding performance of our product.

If you have any questions regarding the operation of the machine, please contact Kernlochbohrer GmbH directly. We are always available to answer your questions.

1.2 Using the Operating instructions

The machine is intended for professional use and may only be operated by trained personnel. Strictly adhere to the instructions in the Operating instructions.

Our company declines all responsibility if the Operating instructions are not followed, which may result in injury or damage to the machine.

The Operating instructions are indispensable for using the machine. The Operating instructions must therefore always be kept in the vicinity of the machine and be accessible to the intended personnel at all times.

In addition to the Operating instructions, the generally applicable and local regulations for accident prevention and environmental protection must be provided; compliance with these regulations must be checked regularly.

1.3 Modifications

Kernlochbohrer GmbH reserves the right to change the design and appearance of the products and their Operating instructions. Future changes to the Operating instructions will be made without prior notice.

1.4 Explanation of symbols



This symbol draws your attention to dangers that you must observe when carrying out the following work in order to avoid damage to yourself, other persons or property.



Cross-reference to another point in the Operating instructions.



Prerequisite for an action.



Action to be performed.



Behaviour of the machine that is to be expected as a result of the preceding action.



Background information or reference to special features.

1.5 Warranty

In accordance with Kernlochbohrer GmbH's general terms of delivery, a warranty period of 12 months applies for material defects in business transactions with companies (proof by invoice or delivery note).

Damage caused by natural wear and tear, overloading or improper handling is excluded.

Damage caused by material or manufacturer defects shall be remedied free of charge by repair or replacement delivery. Complaints can only be recognised if the device is sent to Kernlochbohrer GmbH unassembled.

Wear parts are excluded from the warranty.

1.6 Environmental protection

1.6.1 Disposal of the product

Follow national regulations for environmentally friendly disposal and recycling of disused machines and accessories.

Only for EU countries:

Do not dispose of the machine with household waste! In accordance with European Directive 2012/19/EU on waste electrical and electronic equipment and its transposition into national law, used power tools must be collected separately and recycled in an environmentally friendly manner.

1.6.2 Disposal of the packaging

The packaging is made of recyclable materials. It must be disposed of in accordance with local regulations and labelled accordingly.

1.7 Service

Precise information and specific questions allow faults to be rectified quickly, make it easier to order spare parts and prevent incorrect deliveries.

Before contacting the service department, please collect the following information.

The model designation must be stated for all questions and orders. This information can be found on the type plate of the machine.

Further information is required in the event of faults: type and extent of the fault, accompanying circumstances, suspected cause.

When ordering spare parts, the following is required: Quantity and item number in the exploded view of these Operating instructions.

- ① You are welcome to send us photos when ordering spare parts or videos in the event of faults.

Contact details:

Kernlochbohrer GmbH

Geigersbühlweg 52

72663 Großbettlingen

Germany

Phone: +49 (0)70 22 / 50 34 900

E-Mail: info@kernlochbohrer.com

Internet: <http://www.kernlochbohrer.com>

2 Safety and security

2.1 General information

The machine was built according to the state of the art and in compliance with the applicable laws, standards and safety regulations. Nevertheless, the use of the machine can result in hazards for the user or third parties as well as damage to the machine and other property.

The machine may only be used if it is in perfect working order and in accordance with its intended use, with due regard for safety and hazards.

If the machine is damaged or malfunctions, switch it off immediately, secure it against being switched on again and repair it or arrange for it to be repaired.

2.2 Intended use

The machine is intended exclusively for milling grooves in floor surfaces. These grooves can then be used for laying underfloor heating pipes, for example.

The milling of grooves in floor surfaces can be carried out using the dry or wet method:

- If the dry method is used, the resulting milling dust must be removed using a suitable industrial Hoover.
- A water supply can be connected to the machine for milling grooves using the wet method.

The machine may only be used within the limits of its technical data. This information, for example performance data and ambient conditions, can be found in the "Technical data" chapter.

Any other use or use beyond this is considered improper use - risk of accident! Kernlochbohrer GmbH is not liable for any resulting damage. The risk is borne solely by the operator.

Intended use also includes observing the Operating instructions and complying with the prescribed maintenance intervals.

2.3 Safety regulations for the operator

2.3.1 Organisational safety measures

The Operating instructions must always be available to operating and maintenance personnel. It must therefore always be kept at the machine's place of use.

The accident prevention and environmental protection regulations applicable at the machine's place of use must also be available. The operator of the machine must regularly check compliance with these regulations.

The use of sound-emitting machines may be limited in time by national or local regulations.

The machine must not be operated in potentially explosive atmospheres or in the vicinity of flammable liquids or gases or combustible dust.

All safety and danger notices on the machine must be legible and must not be removed.

The protective equipment required for operating the machine must be provided by the operator. The operator must ensure that the protective equipment is used properly by the personnel.

Operating and auxiliary materials, such as lubricants or cleaning agents, must be selected in such a way that the limit values for hazardous substances applicable at the place of use are complied with. The regulations for environmental protection and disposal applicable at the place of use must be complied with.

2.3.2 Modifications to the machine

The operator may not make any modifications to the machine without written authorisation from Kernlochbohrer GmbH. If the operator carries out modifications without authorisation, the warranty will be invalidated. Kernlochbohrer GmbH is not liable for damage caused by unauthorised modifications.

2.3.3 Spare parts

Spare parts must comply with the properties defined by Kernlochbohrer GmbH. This is always guaranteed for spare parts supplied by Kernlochbohrer GmbH. Kernlochbohrer GmbH is not liable for damage caused by the use of unsuitable spare parts.

2.3.4 Personnel

All persons who are authorised to commission, operate and maintain the machine must have read and understood the Operating instructions beforehand.

The machine may only be operated by persons who have been adequately instructed beforehand.

Maintenance of the machine may only be carried out by persons who have completed specialised training appropriate to this activity.

Minors may not work with the machine. This regulation does not apply to young people over the age of 16 who are trained under supervision.

2.4 Safety regulations for personnel

2.4.1 Safe behaviour

All persons responsible for commissioning, operating and maintaining the machine must have read and understood the Operating instructions beforehand.

The machine may only be operated by persons who have been adequately instructed beforehand.

The machine may only be serviced by persons who have completed the appropriate specialised training.

Minors may not work with the machine. This regulation does not apply to young people over the age of 16 who are trained under supervision.

Any work on or with the machine that could jeopardise safety must be avoided.

All safety and danger notices on the machine must be legible and must not be removed.

2.4.2 Safe operation

Operating the machine requires the full concentration and ability of the personnel. Persons who are overtired, unable to concentrate or under the influence of alcohol, drugs or medication must not work on or with the machine.

Persons who are not directly required to operate the machine must maintain a sufficient safety distance from the machine.

Before using the machine, check that it is in perfect condition. If the machine is damaged, it must not be used. Then secure the machine against use and repair it or arrange for it to be repaired.

In order not to jeopardise the functionality and safety of the machine, covers or other components of the machine must not be removed.

Before starting or starting up the machine, ensure that persons are not endangered by the starting machine.

Operating elements must not be actuated thoughtlessly or wilfully. This could result in personal injury or damage to the machine.

When using the machine, personnel must ensure that they are standing securely and in an ergonomic posture. The machine must always be operated with both hands.

The machine must not be left unattended during use.

Stopping the machine during operation with a heavy load must be avoided. This could lead to damage due to overheating.

Air inlet and outlet openings must not be covered during use.

Do not use the machine in a damp environment and never immerse it in water.

The machine must be cleaned regularly so that dirt does not build up. All controls and handles must be kept clean, dry and free of grease.

When the machine is not in use, it must be parked in such a way that nobody is endangered. Secure the machine against unauthorised use.

2.4.3 Protective equipment

Persons using the machine must wear the following protective equipment:

- Safety shoes with non-slip soles and protective toecaps
- Safety goggles in accordance with standard EN 166 or face protection
- Hearing protection

Milling discs are sharp-edged! Cut-resistant gloves must be worn when handling milling discs.



Silica is a basic component of sand, quartz, brick clay, granite and numerous other materials and rocks.

When cutting materials containing silica, dust and aerosols containing crystalline silica may be produced.

Repeated and/or significant inhalation of crystalline silica can lead to serious or fatal respiratory diseases.

The formation of harmful dust must be prevented by technical means (wet process or dry process with dust extraction). If this is not possible, the operating personnel and bystanders must always wear a respirator approved for the material being processed.

Loose-fitting clothing, long hair or body jewellery can get caught on moving parts of the machine!

Persons carrying out maintenance work on the machine are obliged to wear the appropriate protective equipment required for this activity.

2.5 Safety during maintenance

2.5.1 General information

The machine may only be serviced by persons who have completed the appropriate specialised training for this activity.

The maintenance activities and intervals specified in the Operating instructions must be observed.

Workshop equipment appropriate to the type of work is required to carry out maintenance work.

The following safety precautions must be taken before starting maintenance work:

- Position the machine so that the access point is easily accessible.
- Bring the machine into the appropriate operating state.

After completing maintenance work:

- Assemble the machine completely.
- If operating elements or safety devices have been removed, they must be refitted and their function checked.
- Retighten any screw connections that have been loosened. Re-apply screw locks.

Persons carrying out maintenance work on the machine are obliged to wear the appropriate protective equipment required for this work.

2.5.2 Cleaning

No corrosive, harmful or environmentally damaging substances may be used to clean the machine.

Dispose of cleaning agents in an environmentally friendly manner.

Under no circumstances may high-pressure cleaners, water jets or compressed air be used to clean the machine.

3 Technical data

Article number	8000
Spindle motor power	4000 W
Feed motor power	2x 350 W
Voltage	400 V \pm 5% / 50 Hz
Motor speed	2800 1/min
Spindle speed at idle	8300 1/min
Milling disc: Maximum diameter	130 mm
Milling disc: Width	13 - 17 mm
Cutting depth	0 - 25 mm
Feed speed	0 - 7.5 m/min
Minimum distance of the groove to the wall	120 mm
Dimensions in working position (L x W x H)	Approx. 500 x 480 x 1140 mm
Folded dimensions (L x W x H)	Approx. 600 x 550 x 700 mm
Weight	90 kg
Permissible ambient temperature	5°C to 40°C
Permissible relative humidity	30% to 80%
Protection class	IP 55
Connector plug according to IEC 60309	CEE 400 V / 16 A
Connection cable required	H05RN-F 3G 2.5 or H05BQ-F 3G 2.5 or better
Sound power level L_{weq} when idling	> 80 dB(A)
Hand/arm vibration according to EN 61029	< 1 m/s ²
Water supply connection	Gardena®
Dust extraction connection	D= 50 mm / d= 45 mm

4 Machine description

4.1 Machine components

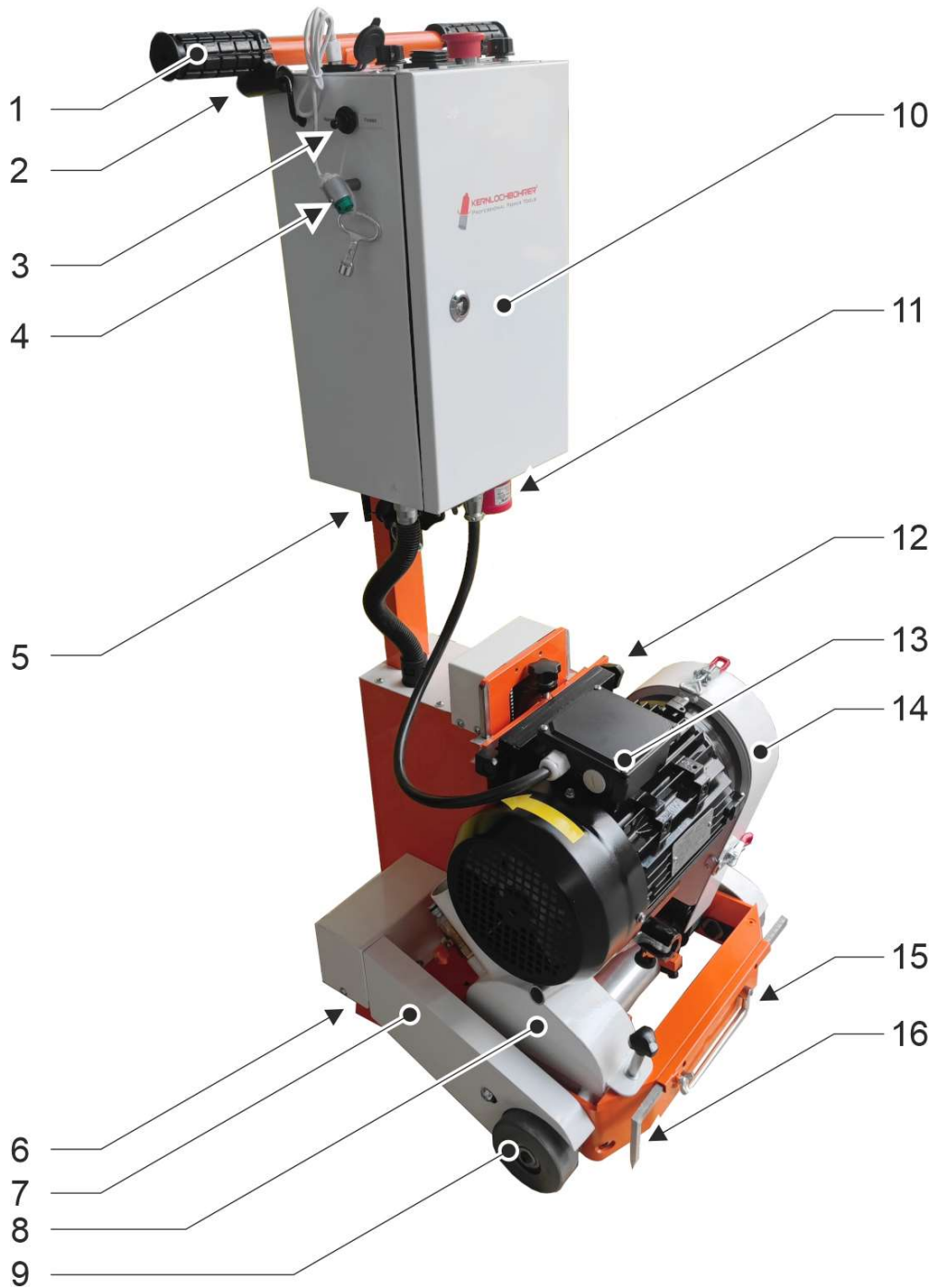

- 1 Operating handle (2 pieces)
- 2 Feed button (2 pieces)
- 3 Feed direction selector switch
- 4 Laser pointer
- 5 Upper part of operating arm lock
- 6 Fixed castor (2 pieces)
- 7 Feed drive cover
- 8 Milling disc cover
- 9 Feed wheel (2 pieces)
- 10 Switch box
- 11 Connector plug
- 12 Mounting spindle motor
- 13 Spindle motor
- 14 Spindle drive cover
- 15 Transport handle (foldable)
- 16 Ruler

4.2 Operating elements



- 1 Switch for spindle motor
- 2 Left feed speed setting
- 3 Milling depth display
- 4 Emergency stop button
- 5 Milling depth adjustment
- 6 USB socket for laser pointer
- 7 Setting the feed speed on the right
- 8 Operating handle left
- 9 Left feed button
- 10 Feed right button
- 11 Operating handle right

4.3 Explanations of machine components and operating elements

4.3.1 Connecting plug

The machine is connected to the power supply using the connection plug.

A connection cable of type H05RN-F 3G2.5, H05BQ-F 3G2.5 or better with a socket (CEE 400 V / 16 A) must be used for this purpose.



When the machine is not in use, the socket of the connection cable must be removed from the connection plug.

This is particularly important before carrying out maintenance work!

4.3.2 Emergency stop button

The emergency stop button is used to quickly switch off the spindle motor in an emergency or dangerous situation.



After pressing the emergency stop button, the milling disc slowly coasts to a stop.

Keep your distance from the milling disc until the milling disc has come to a complete stop.

To release the emergency stop button, turn the operating knob.

4.3.3 Switch for spindle motor

The switch is used to switch the spindle motor and therefore also the milling disc on and off.

When the switch is switched on, the drive motor starts up and sets the milling disc in rotation.



After switching off the switch for the spindle motor, the milling disc slowly coasts to a stop.

Keep your distance from the milling disc until the milling disc has come to a complete stop.

4.3.4 Milling depth display

The display is used to set the milling depth; after clearing the display, it shows the relative depth adjustment of the milling disc.

ON/OFF Display is switched on or off.

In/mm Switches the unit of measurement between millimetres and inches. The selected unit of measurement is shown in the display.

ZERO Resets the display to zero

SET Without function

ABS Without function

① The display is powered by its own batteries. To save the batteries, the display must be switched off separately.

4.3.5 Adjusting the milling depth

The switch for adjusting the milling depth can be used to move the milling disc up or down.

The movement is executed as long as the switch is pressed.

Up The milling disc moves upwards.

Down The milling disc moves downwards.

4.3.6 Laser pointer

The laser pointer generates a beam of light on the floor surface in front of the machine.

If this light beam is guided over the desired path (marking on the floor) when milling the groove, the groove is created at the desired position.

The laser pointer is powered via the USB socket.

4.4 Further interfaces



Interfaces

- 1 Connection for water supply with coupling and ball valve
- 2 Connection for dust extraction

4.4.1 Connection for dust extraction



Health hazard!

The harmful dust produced when milling grooves using the dry method must be extracted using a suitable industrial Hoover!

If the machine is to be used in a dry process, the dust must be extracted.

To do this, connect an industrial Hoover to the machine connection (D = 50 mm / d = 45 mm).

- ① For dust extraction, Kernlochbohrer GmbH recommends the use of our industrial dry vacuum cleaner TS-2000/PRO or a device of equivalent performance.



If the connection for dust extraction is not used, it must be sealed with the dust protection cap supplied!

4.4.2 Connection for water supply

As an alternative to the dry process, the machine can also be used in the wet process.



Health hazard!

If the harmful dust produced when milling grooves is not removed by an industrial Hoover, it must be bound by water!

If the machine is to be used in a wet process, the water supply must be established.

To do this, connect a water hose with a Gardena® quick-release coupling to the connector on the machine.

The ball valve can be used to stop the water supply completely or to regulate the water flow.

4.5 Scope of delivery

The scope of delivery of the machine includes the following components:

- T-REX underfloor heating milling machine
- Open-end spanner SW 18
- Open-end spanner SW 24
- Spanner for switch box
- Operating instructions

- ① The milling disc required to use the machine must be purchased separately.

Kernlochbohrer GmbH offers an extensive range of tools and accessories for the machine. The webshop <http://www.kernlochbohrer.com> is available for information and ordering.

5 Use of the machine

5.1 Specific precautions



Milling grooves in floor surfaces can be carried out using the dry or wet method:

The harmful dust produced when milling grooves using the dry method must be extracted using a suitable industrial Hoover!

If the harmful dust produced when milling grooves is not removed by an industrial Hoover, it must be bound by water!



When the machine is not in use, the socket of the connection cable must be removed from the connection plug.

This is particularly important before carrying out maintenance work!



Risk of electric shock!

The machine does not have the appropriate degree of protection and must therefore not be operated in wet rooms (e.g. bathrooms or laundry rooms) or outdoor areas.

The machine may only be operated indoors.

To avoid damage or overloading, do not place any objects on the machine.

If a fault occurs during operation of the machine (e.g. smell of burning), switch off the machine immediately and disconnect the mains cable from the plug.

Otherwise a fire, electric shock or other incident could occur. The machine must not be switched on again until the fault has been rectified and the machine is functioning correctly.

5.2 Transporting the machine

Before transporting the machine:

- Remove the milling disc or move it to the upper end position.
- Remove the mains cable from the connection plug.
- Disconnect the water supply or dust extraction system.

5.2.1 Transport on fixed castors

To do this, hold the machine by both operating handles, tilt it backwards and push it onto the fixed castors (at the rear of the frame).

Park the machine carefully and only release the operating handles when the machine is securely on the ground.

5.2.2 Transport with the upper part of the operating arm folded down

The upper part of the operating arm of the machine can be folded down for transport.

To do this, open the lock on the upper part of the operating arm and fold the upper part downwards.



The upper part of the operating arm is now no longer fixed!

The machine cannot be rolled or carried by the upper part of the operating arm in this state.

Finally, fold the upper part of the operating arm upwards and lock it in this position.

5.2.3 Transporting the individual components

The machine can also be dismantled into its main components for transport.

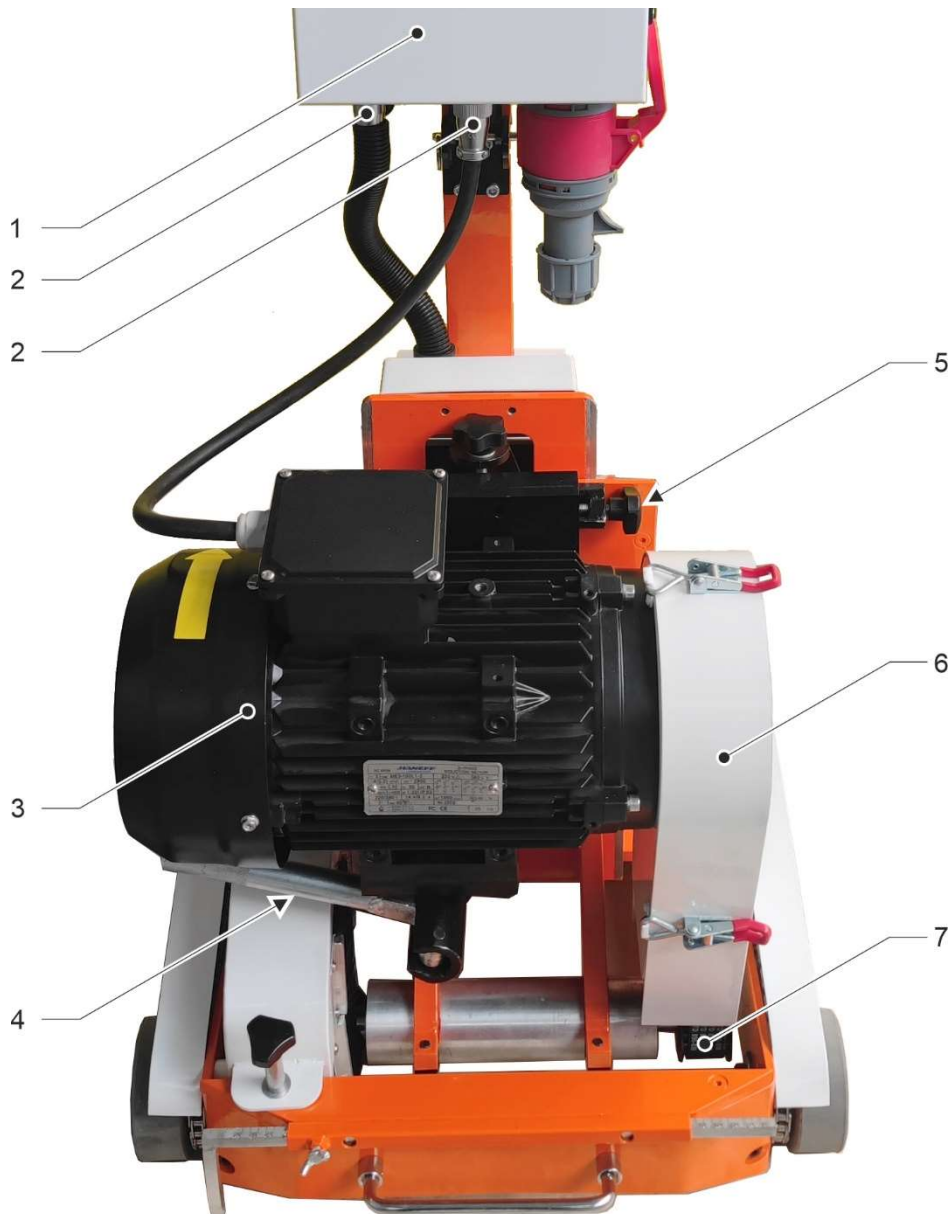

- 1 Switch box
- 2 Connecting cable
- 3 Spindle motor
- 4 Clamping lever

- 5 Clamping screw
- 6 Spindle drive cover
- 7 Drive belt

Remove upper part of operating arm

- Disconnect both connecting cables at the control box.
- Fold down the upper part of the operating arm.

Remove the cotter pin on the hinge of the upper part of the operating arm and remove the upper part.

Remove the spindle motor

- Remove the cover of the spindle drive.
- Loosen the clamping screw of the motor fixation.
- Pull the clamping lever of the motor fixation forwards.
 - ↳ The spindle motor folds down.
- Remove the drive belt.
- Push the spindle motor (weight approx. 30 kg) in the direction of the drive belt and lift it upwards out of the holder.

The machine must be reassembled in reverse order.

5.3 Working with the machine

5.3.1 Visual inspection of the machine

Before working with the machine, it must be visually inspected:

- Check the general condition and cleanliness of the machine.
- Check the presence of all covers and machine components.
- Check that all screws are tight.
- Air inlet and outlet openings must not be dirty or covered.
- The mains cable and connection plug must not be damaged.

5.3.2 Fitting the milling disc



Milling discs are sharp-edged!

Cut-resistant gloves must be worn when handling milling discs.

Pay attention to the following points for optimum work results:

- Suitability of the milling disc for the material to be processed.
- Condition of the milling disc. Never use a damaged or worn milling disc.
- Correct mounting of the milling disc.



Milling disc mounted on spindle

- 1 Collar nut
- 2 Outer spacer disc
- 3 Milling disc

Prerequisites:

- Mains cable socket removed from connector plug.
- Visual inspection of the machine performed.
 -  See chapter 5.3.1 "Visual inspection of the machine".

Procedure:

- Remove the cover of the milling disc.
- Remove the collar nut from the spindle. The spindle can be held against the double flat with an 18 mm open-end spanner.
- Remove the outer spacer disc from the spindle.
- Fit the milling disc onto the spindle.
- Fit the outer spacer disc onto the spindle.
- Fit the collar nut onto the spindle and screw tight. Hold the spindle against the double flat.
- Fit the milling disc cover.

5.3.3 Electrical connection

Observe the following points:

- Observe the electrical connection values of the appliance.
 See chapter 3 "Technical data".
- The mains cable and connection plug must not be damaged.
- Damaged plugs may only be replaced by Kernlochbohrer GmbH or a qualified electrician.
- The mains cable socket and connecting plug must be clean and dust-free.
- The supplied electrical voltage must not deviate by more than 5% from the nominal value. Excessive voltages can cause irreparable damage to the machine.
- Voltage peaks must not occur when operating the machine with power generators.
- When connecting the machine to the mains, a residual current device (RCD) with a maximum tripping current of 30 mA must be connected upstream.
- The machine is equipped with a CEE 400 V / 16 A connection plug. The machines may only be operated using a mains cable with the corresponding socket.
- The mains cable must be of type H05RN-F 3G2.5, H05BQ-F 3G2.5 or better.
- When using extension cables, the cable cross-section must be suitable for the power consumption of the machine.
- When using a cable reel, the cable must always be fully unwound.
- To remove the mains cable from the plug, grasp the socket. Do not pull on the cable.
- If the machine is not to be used for a longer period of time, switch off the machine and remove the power cable socket from the plug.





5.3.4 Using the machine



The generation of harmful dust must be prevented by technical means (wet process or dry process with dust extraction).

If this is not possible, the operating personnel and bystanders must always wear a respirator approved for the material being processed.

Prerequisites:

- ☑ Visual inspection of the machine performed.
 See chapter 5.3.1 "Visual inspection of the machine".
- ☑ Milling disc fitted.
 See chapter 5.3.2 "Fitting the milling disc milling disc".
- ☑ Dust extraction system connected and switched on or water supply established.
 See chapter 4.4 "Further interfaces".
- ☑ Electrical connection of the machine established.
 See chapter 5.3.3 "Electrical connection".

Procedure:

- ☒ Move the machine to the floor surface to be processed and set it up at the desired groove position.
- ☒ Use the milling depth switch to move the milling disc all the way up or tilt the machine slightly backwards so that the spindle motor can start up without load.
- ☒ Start the machine's spindle motor. To do this, press button [1] on the switch.
 The spindle motor is switched on and the milling disc begins to rotate.

- ☒ Check the direction of rotation of the spindle motor on its fan wheel.



The direction of rotation must correspond to the direction of the arrow on the motor housing. If the direction of rotation of the fan wheel or spindle motor does not match the direction of the arrow, the direction of rotation must be changed manually:



The direction of rotation of the spindle motor may only be changed by a qualified electrician!

- ☒ Switch off the machine and remove the mains cable socket from the connecting plug.
 - 📖 See chapter 5.3.5 "Switching off the machine".
- ☒ To change the direction of rotation of the spindle motor, two of the three outer conductors must be swapped. This change can be made either directly at the motor connection or at the connection plug.
- ☒ Then reconnect the machine's electrical connection.
- ☒ Start the spindle motor of the machine.
- ☒ Check the direction of rotation of the spindle motor on its fan wheel again.

- ☒ When the machine has reached its rated speed:
Check the emergency stop function of the machine:
 - ☒ Press the emergency stop button.
 - ↪ The spindle motor is switched off.
-  After switching off the switch for the spindle motor, the milling disc slowly coasts to a stop.
Keep your distance from the milling disc until the milling disc has come to a complete stop.
- ☒ Check whether the spindle motor stops.
If the spindle motor is not switched off after pressing the emergency stop button, have the machine repaired by Kernlochbohrer GmbH or a qualified electrician.
Do not operate the machine in this state!
- ☒ Unlock the emergency stop button.
- ☒ Restart the spindle motor of the machine.
- ☒ When the machine has reached its nominal speed:
Set the desired milling depth (0 - 25 mm):
 - ☒ Use the milling depth switch to move the milling disc downwards until it lightly touches the ground surface .
 - ☒ Switch on the display for the milling depth by pressing the [ON/OFF] button. The display shows the value zero.
 - ☒ Use the milling depth switch to move the milling disc downwards until the desired milling depth is reached.
- ☒ Plug the laser pointer cable into the USB socket.
- ☒ Set the feed direction selector switch to "Forward".
- ☒ Set the desired feed speed using the two feed speed control dials.
- ☒ Hold both operating handles firmly.
- ☒ Press both feed buttons.
- ↪ The machine starts moving and begins milling the groove.
- ☒ The machine can follow a curved path by steering using the operating handles or by adjusting the feed speed on one side.

5.3.5 Switching off the machine

Procedure:

- ☒ Release both feed buttons.
- ↵ The feed movement of the machine stops.
- ☒ Set the feed speed to zero on the two control dials.
- ☒ Switch off the machine spindle motor. To do this, press the [0] button on the switch.



After switching off the spindle motor, the milling disc slowly coasts to a stop.

Keep your distance from the milling disc until the milling disc has come to a complete stop.

- ☒ Use the milling depth switch to move the milling disc all the way up.
- ☒ Switch off the display for the milling depth by pressing the [ON/OFF] button.
- ☒ Disconnect the laser pointer cable from the USB socket.
- ☒ Remove the mains cable socket from the connector plug.
- ☒ Switch off dust extraction or water supply and disconnect from machine.
- ☒ Check the machine for soiling. Clean the machine if necessary.
 - 📖 See chapter 6.3.1 "Cleaning the machine and checking".
- ☒ Remove the cover of the milling disc.
- ☒ Check the condition and fastening of the milling disc.
- ☒ Replace damaged or worn milling disc.
 - 📖 See chapter 5.3.2 "Fitting the milling disc milling disc".
- ☒ Fit the milling disc cover.

5.3.6 Storing the machine

Procedure:

- ☑ Switch off the machine.
 - 📖 See chapter 5.3.5 "Switching off the machine".
- ☑ Clean the machine and allow to dry completely.
 - 📖 See chapter 6.3.1 "Cleaning the machine and checking".
- ☑ Remove the milling disc from the spindle.
 - 📖 See chapter 5.3.2 "Fitting the milling disc milling disc".
- ☑ Switch off the machine and secure it against falling over.
- ☑ Store the machine in a dry, cool place protected from moisture and direct sunlight.
- ☑ Secure the machine against unauthorised use.

6 Maintenance

6.1 Notes on proper maintenance

Insufficient or improper maintenance can cause malfunctions and impair the operational safety and service life of the machine. Regular inspection and maintenance is therefore essential. We recommend that maintenance work is only carried out by trained personnel.

The contractually agreed warranty does not release the operator of the machine from the obligation to maintain the machine in accordance with the manufacturer's instructions from the time of commissioning. Kernlochbohrer GmbH is not liable for damage caused by a lack of maintenance.

6.2 Maintenance and inspection schedule

The interval specifications refer to normal operating conditions. In more difficult conditions (heavy dust etc.) and longer daily working times, the specified intervals must be shortened accordingly by the operator.

Use the maintenance and inspection schedule only as a guide! Always follow the cross-references to the other chapters! They contain detailed descriptions of how to carry out the individual tasks correctly and safely.

Interval	Category	Component	Activity	Chapter
1 day	Real time	Machine	Cleaning and testing	6.3.1

6.3 Inspection and maintenance

6.3.1 Cleaning the machine and checking



Do not use sharp sponges or metal objects to clean the machine. These could damage the surface of the machine.

Do not use high-pressure cleaners, water jets or compressed air to clean the machine. The sharp water or air jet could damage the machine.

Do not use any corrosive, harmful or environmentally damaging substances to clean the machine.

Interval:

1 day Real time

Auxiliary means:

- Container with a mixture of water and mild detergent (e.g. washing-up liquid).
- Cloth and brush

Procedure:

- Remove the mains cable socket from the plug.
 -  See chapter 5.3.5 "Switching off the machine".
- Clean the machine of dust and dirt.
 - To do this, use a damp cloth dipped in water mixed with a mild detergent.
 - Do not allow water to enter the interior of the drive motor via the air inlet and outlet openings.

- ☒ Clean the air inlet and outlet openings of the drive motor with a brush and damp cloth.
- ☒ Allow the machine to dry completely.
- ☒ Check the tightness of all screws on the machine. If necessary, tighten the screws.
- ☒ Check the condition and tension of the drive belt:
 - ☒ Remove the cover of the spindle drive.
 - ☒ Check the condition of the drive belt. Replace damaged drive belt.
 - ☒ Check the tension of the drive belt. Re-tension the drive belt if necessary.
 - ☒ Attach the spindle drive cover.

7 Troubleshooting

If a fault occurs during operation of the machine, please first try to rectify the fault yourself using the following information.

If you are unable to rectify the fault yourself, please contact Kernlochbohrer GmbH.

Fault	Possible cause	Troubleshooting
No function	No power supply	Check power supply
Spindle motor is running, but milling disc is stationary	Spindle drive belt loose or torn	Check and retighten or replace the spindle drive belt

8 Spare parts

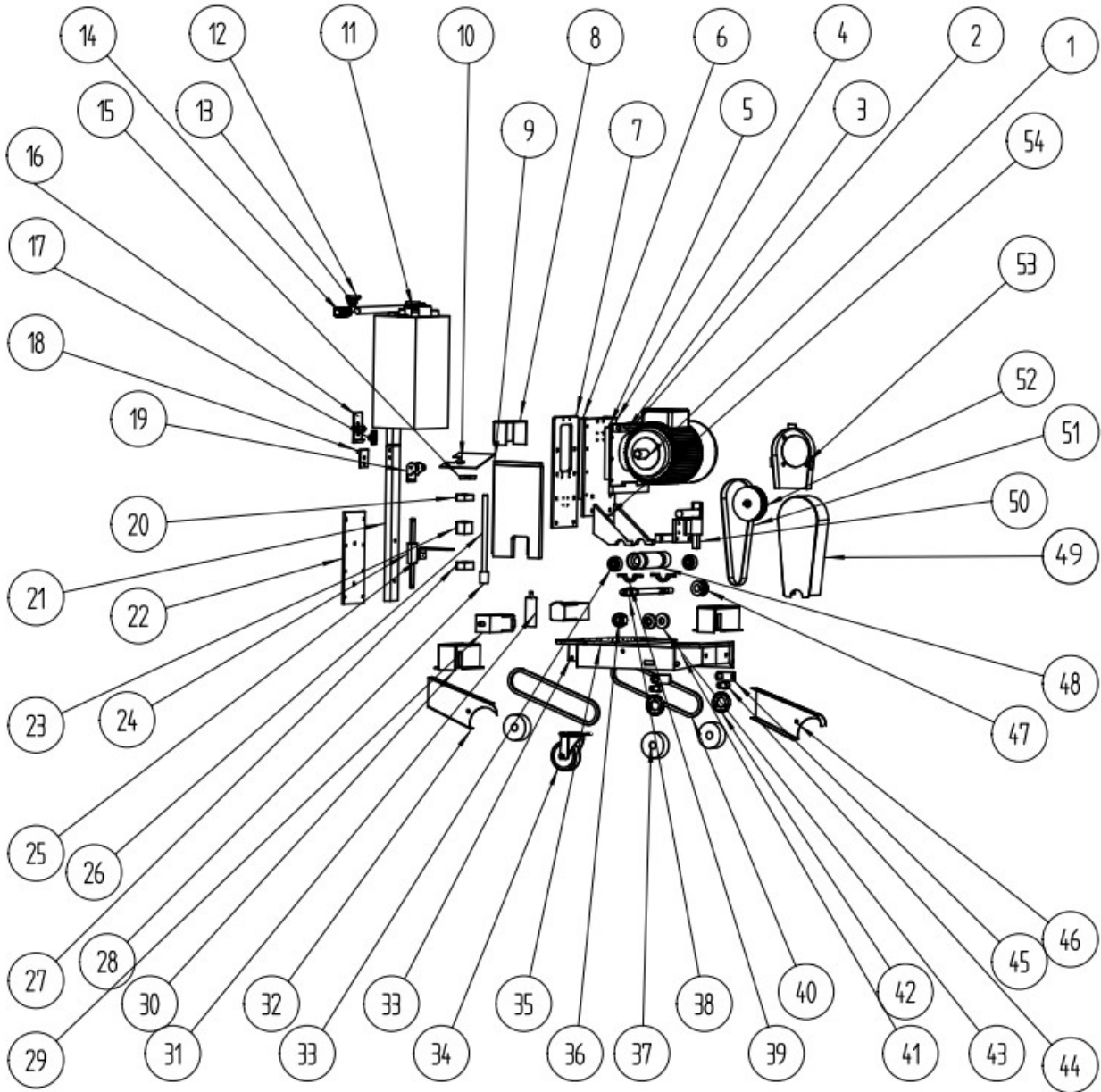

No.	Description	Piece
1	Spindle motor	1
2	Motor base plate	1
3	Motor mounting device	1
4	Slider for lifting	1
5	Small slider	2
6	Large slider	2
7	Slider base plate	1
8	Bearing base cover	1
9	Vertical main plate	2
10	Upper guard plate	1
11	Switch box	1
12	Left and right rotary knob	2
13	Handle	1
14	Handle cover	2
15	Upper bearing bracket	1
16	Folding clasp	1
17	Folding stand	1
18	Folding hook	1
19	Folding hinge	1
20	Upper bearing base	1
21	Lower arm	1
22	Lower arm mounting plate	1
23	Lifting carriage	1
24	Depth scale	1
25	Connection for depth gauge	1
26	Spindle for lifting device	1
27	Lower bearing bracket	1

No.	Description	piece
28	Coupling piece	1
29	Stepper motor	2
30	Protective cover for stepper motor	2
31	Lifting motor	1
32	Chain guard cover right	1
33	Chassis bracket	1
34	Universal wheel	1
35	Base plate	1
36	Lock nut of the milling disc	1
37	Wheel	2
38	Main shaft	1
39	Socket terminals	2
40	Chain	2
41	Reference ruler	1
42	Pinion plate	2
43	Clamp for milling disc	2
44	Wheel shaft	2
45	Sealing plate for the shaft	2
46	Chain guard cover left	1
47	Main shaft synchronising wheel	1
48	Sleeve of the main shaft	1
49	Timing belt guard cover	1
50	Push-pull device	1
51	Synchronised belt	1
52	Motor synchronising wheel	1
53	Synchronising belt guard Base	1
54	Mounting of the shaft sleeve	2

9 EU Declaration of Conformity

The manufacturer/distributor

Kernlochbohrer GmbH
Geigersbühlweg 52
72663 Großbettlingen
Germany

hereby declares that the following product

Product designation: **Underfloor heating milling machine**

Type: **T-REX**

complies with all relevant provisions of the applicable legislation (hereinafter), including any amendments thereto in force at the date of the declaration. This declaration of conformity is issued under the sole responsibility of the manufacturer. This declaration relates only to the machine in the condition in which it was placed on the market; parts and/or modifications subsequently fitted by the end user are not taken into account.

The following legal regulations have been applied:

Machinery Directive 2006/42/EU

Electromagnetic Compatibility Directive 2014/30/EU

The following harmonised standards have been applied:

EN ISO 12100:2010 Safety of machinery - General principles for design - Risk assessment and risk reduction

EN 60204-1:2018 Safety of machinery - Electrical equipment of machines - Part 1: General requirements

Name and address of the person authorised to compile the technical documentation

Kernlochbohrer GmbH
Geigersbühlweg 52
72663 Großbettlingen
Germany

Großbettlingen 30.06.2025

Kernlochbohrer GmbH

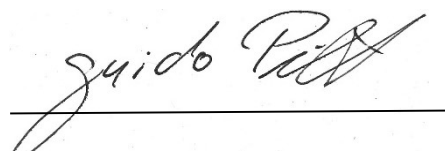

Guido Pillat
Managing Director / Chief Executive Officer